

Write your name here

Surname

Other names

Pearson Edexcel
International
Advanced Level

Centre Number

--	--	--	--	--

Candidate Number

--	--	--	--	--

Mechanics M1

Advanced/Advanced Subsidiary

Monday 22 January 2018 – Afternoon
Time: 1 hour 30 minutes

Paper Reference

WME01/01

You must have:

Mathematical Formulae and Statistical Tables (Blue)

Total Marks

--

Candidates may use any calculator allowed by the regulations of the Joint Council for Qualifications. Calculators must not have the facility for symbolic algebra manipulation, differentiation and integration, or have retrievable mathematical formulae stored in them.

Instructions

- Use **black** ink or ball-point pen.
- If pencil is used for diagrams/sketches/graphs it must be dark (HB or B). Coloured pencils and highlighter pens must not be used.
- **Fill in the boxes** at the top of this page with your name, centre number and candidate number.
- Answer **all** questions and ensure that your answers to parts of questions are clearly labelled.
- Answer the questions in the spaces provided
– *there may be more space than you need.*
- You should show sufficient working to make your methods clear. Answers without working may not gain full credit.
- Whenever a numerical value of g is required, take $g = 9.8 \text{ m s}^{-2}$, and give your answer to either two significant figures or three significant figures.
- When a calculator is used, the answer should be given to an appropriate degree of accuracy.

Information

- The total mark for this paper is 75.
- The marks for **each** question are shown in brackets
– *use this as a guide as to how much time to spend on each question.*

Advice

- Read each question carefully before you start to answer it.
- Try to answer every question.
- Check your answers if you have time at the end.

Turn over ►

P51463A

©2018 Pearson Education Ltd.

1/1/1/



Pearson

1.

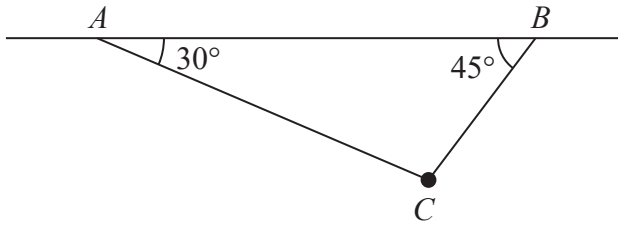

Figure 1

A particle of weight W is attached at C to two light inextensible strings AC and BC . The other ends of the strings are attached to fixed points A and B on a horizontal ceiling. The particle hangs in equilibrium with the strings in a vertical plane and with AC and BC inclined to the horizontal at 30° and 45° respectively, as shown in Figure 1.

Find, in terms of W ,

- (i) the tension in AC ,
- (ii) the tension in BC .

(7)

DO NOT WRITE IN THIS AREA

DO NOT WRITE IN THIS AREA

DO NOT WRITE IN THIS AREA



2.

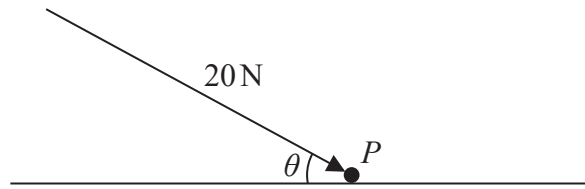

Figure 2

A particle P of weight 40 N lies at rest in equilibrium on a fixed rough horizontal surface. A force of magnitude 20 N is applied to P . The force acts at angle θ to the horizontal, as shown in Figure 2. The coefficient of friction between P and the surface is μ .

Given that the particle remains at rest, show that

$$\mu \geq \frac{\cos \theta}{2 + \sin \theta}$$

(6)

DO NOT WRITE IN THIS AREA

DO NOT WRITE IN THIS AREA

DO NOT WRITE IN THIS AREA



Question 2 continued

DO NOT WRITE IN THIS AREA

DO NOT WRITE IN THIS AREA

DO NOT WRITE IN THIS AREA

Q2

(Total 6 marks)



3. Two particles A and B have mass $2m$ and km respectively. The particles are moving in opposite directions along the same straight smooth horizontal line so that the particles collide directly. Immediately before the collision A has speed $2u$ and B has speed u . The direction of motion of each particle is reversed by the collision. Immediately after the collision the speed of A is $\frac{u}{2}$.

(a) Find, in terms of m and u , the magnitude of the impulse exerted by B on A in the collision. (3)

(b) Show that $k < 5$ (4)



Question 3 continued

DO NOT WRITE IN THIS AREA

DO NOT WRITE IN THIS AREA

DO NOT WRITE IN THIS AREA

A series of 28 horizontal lines provided for writing an answer to Question 3.

(Total 7 marks)

Q3



Leave blank

Question 4 continued

DO NOT WRITE IN THIS AREA

DO NOT WRITE IN THIS AREA

DO NOT WRITE IN THIS AREA

Q4

(Total 8 marks)



5. A cyclist is travelling along a straight horizontal road. The cyclist starts from rest at point A on the road and accelerates uniformly at 0.6 m s^{-2} for 20 seconds. He then moves at constant speed for $4T$ seconds, where $T < 20$. He then decelerates uniformly at 0.3 m s^{-2} and after T seconds passes through point B on the road. The distance from A to B is 705 m.

(a) Sketch a speed-time graph for the motion of the cyclist between points A and B . (2)

(b) Find the value of T . (7)

The cyclist continues his journey, still decelerating uniformly at 0.3 m s^{-2} , until he comes to rest at point C on the road.

(c) Find the total time taken by the cyclist to travel from A to C . (3)



6. [In this question \mathbf{i} and \mathbf{j} are perpendicular horizontal unit vectors.]

A particle P of mass 2 kg moves under the action of two forces, $(2\mathbf{i} + 3\mathbf{j})$ N and $(4\mathbf{i} - 5\mathbf{j})$ N.

(a) Find the magnitude of the acceleration of P .

(4)

At time $t = 0$, P has velocity $(-u\mathbf{i} + u\mathbf{j})$ m s⁻¹, where u is a positive constant.

At time $t = T$ seconds, P has velocity $(10\mathbf{i} + 2\mathbf{j})$ m s⁻¹.

(b) Find

(i) the value of T ,

(ii) the value of u .

(5)

DO NOT WRITE IN THIS AREA

DO NOT WRITE IN THIS AREA

DO NOT WRITE IN THIS AREA



Question 6 continued

Lined area for writing the answer to Question 6.

DO NOT WRITE IN THIS AREA

DO NOT WRITE IN THIS AREA

DO NOT WRITE IN THIS AREA

Q6

(Total 9 marks)



7.

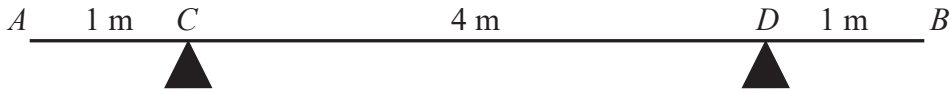

Figure 3

A non-uniform rod AB has length 6 m and mass 8 kg. The rod rests in equilibrium, in a horizontal position, on two smooth supports at C and at D , where $AC = 1$ m and $DB = 1$ m, as shown in Figure 3. The magnitude of the reaction between the rod and the support at D is twice the magnitude of the reaction between the rod and the support at C . The centre of mass of the rod is at G , where $AG = x$ m.

(a) Show that $x = \frac{11}{3}$. (6)

The support at C is moved to the point F on the rod, where $AF = 2$ m. A particle of mass 3 kg is placed on the rod at A . The rod remains horizontal and in equilibrium. The magnitude of the reaction between the rod and the support at D is k times the magnitude of the reaction between the rod and the support at F .

(b) Find the value of k . (6)

DO NOT WRITE IN THIS AREA



Leave blank

Question 7 continued

DO NOT WRITE IN THIS AREA

DO NOT WRITE IN THIS AREA

DO NOT WRITE IN THIS AREA



8.

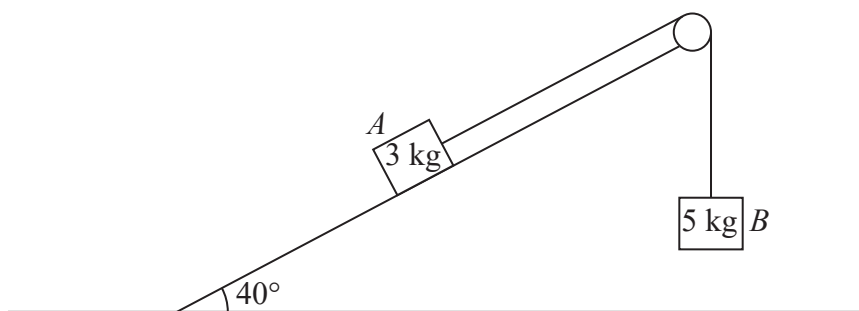

Figure 4

One end of a light inextensible string is attached to a block *A* of mass 3 kg. Block *A* is held at rest on a smooth fixed plane. The plane is inclined at 40° to the horizontal ground. The string lies along a line of greatest slope of the plane and passes over a small smooth pulley which is fixed at the top of the plane. The other end of the string is attached to a block *B* of mass 5 kg. Block *B* hangs freely at rest below the pulley, as shown in Figure 4. The system is released from rest with the string taut.

By modelling the two blocks as particles,

- (a) find the tension in the string as *B* descends. (6)

After falling for 1.5 s, block *B* hits the ground and is immediately brought to rest. In its subsequent motion, *A* does not reach the pulley.

- (b) Find the speed of *B* at the instant it hits the ground. (3)
- (c) Find the total distance moved up the plane by *A* before it comes to instantaneous rest. (5)

DO NOT WRITE IN THIS AREA

DO NOT WRITE IN THIS AREA

DO NOT WRITE IN THIS AREA



Question 8 continued

DO NOT WRITE IN THIS AREA

DO NOT WRITE IN THIS AREA

DO NOT WRITE IN THIS AREA



